

SERVICES GUIDE

# EMPOWERING HYDROPOWER

COMPREHENSIVE SOLUTIONS FOR  
EFFICIENCY & RELIABILITY



# Our Mission



**Helping Yield Sustainable Outcomes through Viable, Efficient, Nature driven Technologies**

Hysovent is a company founded in late 2021, focused on providing engineering and project management consulting services for renewable energy, energy efficiency and sustainability projects and initiatives. Our name is a combination of the three main sources of renewable energy of the mother nature:

HY: Hydro – the power of water

SO: Sol – the power of the sun

VENT: Ventus – the power of the wind

We provide **engineering and project management consulting services** for institutional, commercial and industrial organizations, for **renewable energy, sustainability and energy efficiency projects and initiatives**, from conceptualization to execution, commissioning and closure, including technical supervision during all stages, quality control of deliverables, operational support, and financial management of the project.

Our experience and extensive professional network can tackle a wide variety of multidisciplinary projects, delivering high quality outcomes for your most complex undertakings.

Handwritten signature of Javier Ojeda.

JAVIER OJEDA  
President & Owner



# What is *Hydropower*?

Hydropower, or hydroelectric power, is one of the oldest and largest sources of renewable energy. It uses the natural flow of moving water, like rivers, to generate electricity. Advantages of using a renewable energy source such as hydropower, include:

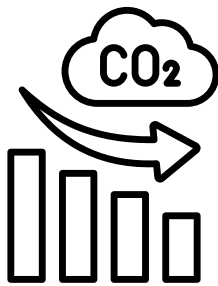

**1** **Low-Emissions:**  
It produces little to no greenhouse gases and air pollutants during operation

**Flexible and Reliable:**  
It can quickly adjust power output to meet demand **2**

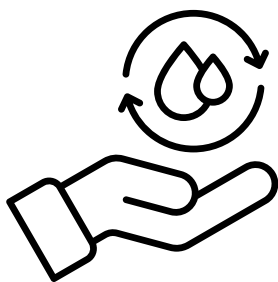

**3** **Water Management:**  
Including flood control, and water storage for drinking water and irrigation

**Long lifespan:**  
Remains operational for decades, increasing energy independence **4**

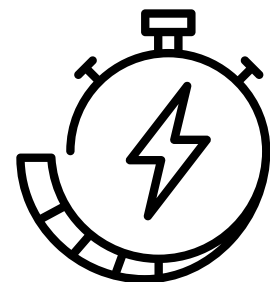

# Services Overview

## FROM START TO FINISH

### *Project Management and Administration*

- Project management for:
  - **Renewable energy projects**, serving communities and both public and private organizations.
  - The **overhaul and maintenance** of renewable energy generation equipment and facilities.
  - Including:
    - **Technical supervision throughout all phases**
    - **QAQC**: planning and execution of QAQC for electromechanical equipment, including FAT and SAT
    - Operation and Maintenance **program design and evaluation**, and
    - **Financial management** of the project



### *Hydro Plant Condition Assessments*

- We conduct detailed evaluations of hydroelectric plants, focusing on turbine and generator efficiency, plant equipment, and civil infrastructure.
- Our assessments offer **insights and recommendations** to enhance facility reliability and longevity.

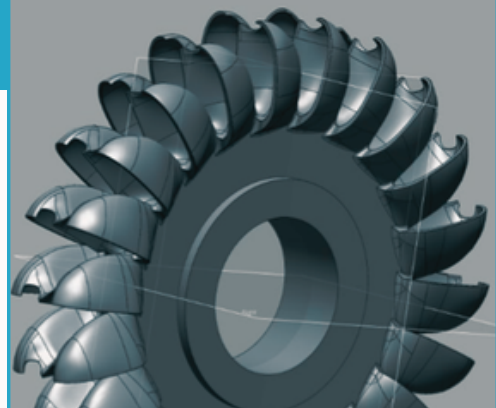

### *Feasibility Studies and Environmental Impact Evaluation*

- Conducting feasibility studies for **new hydropower projects of all sizes**, with a focus on small-scale hydro developments, this includes:
  - Assessing environmental impacts
  - Evaluating potential energy outputs, and
  - Analyzing overall viability

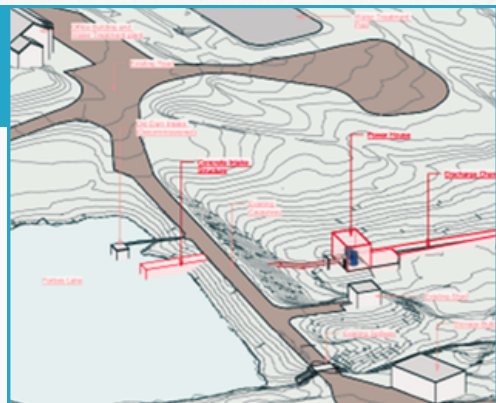

# Specialty Services

## *Mechanical and Electrical Engineering for Power Generation Equipment*

Our specialized services in mechanical and electrical engineering are designed to support and enhance the performance of power generation equipment. Our expertise covers a range of critical components and systems, ensuring optimal operation and reliability. Such as:

- **Turbines:** For the maintenance, repair, and optimization of various types of turbines. Our team ensures that your turbines operate at peak efficiency and reliability.
- **Turbine Components:** Our services extend to individual turbine components, where we apply cutting-edge techniques to enhance performance and lifespan.
- **Generators:** We offer solutions for generators, focusing on improving electrical output and operational stability. Our services include diagnostics, repairs, and upgrades to ensure your generators are running efficiently.
- **Balance of Plant (BOP):** Comprehensive support of auxiliary systems that are essential for the overall functionality of your power generation facility. This includes piping, cooling systems, and control systems, ensuring they operate seamlessly with the primary equipment.

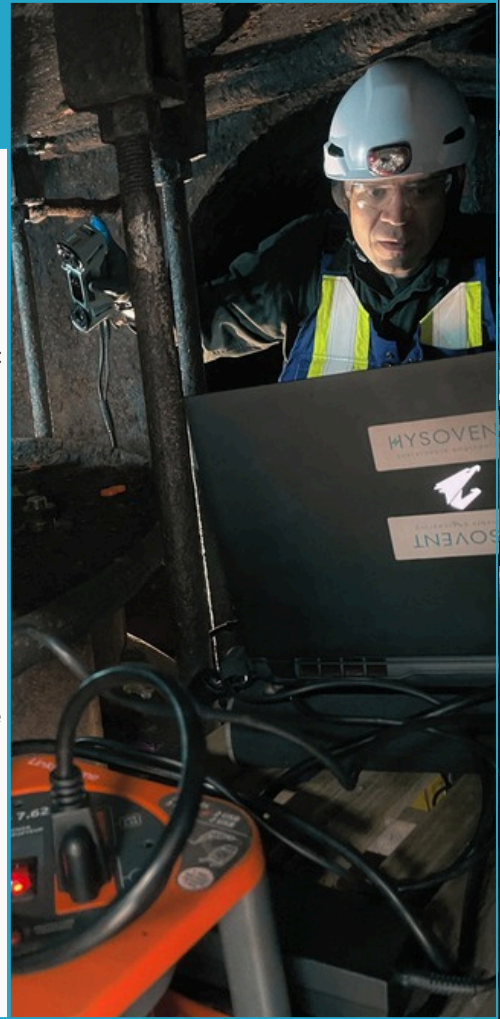

## *Reverse Engineering and 3D Scanning for Mechanical Components*

- This is a service designed to create a **digital twin** of mechanical components, regardless of their condition or size. This service can be used to generate reference drawings for:
  - **Operational guidance**
  - **Repairs** at internal or external facilities
  - **Remodelling:** creating a new piece based on the original with specific modifications
  - **Recasting:** producing a new mold to replicate the original piece exactly
  - **Material strength analysis:** certification of hoists and lifting devices, for example Finite Element Analysis

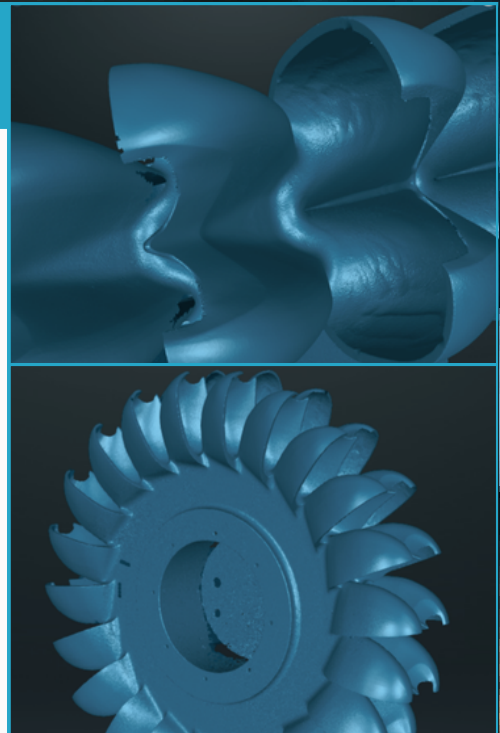

# Specialty Services

## *Forensic Engineering for Hydropower Plants*

Services designed to carefully investigate and analyze failures to ensure the continued safety and efficiency of operations. Key aspects of our services include:

- Conducting thorough **root cause analyses** to identify underlying issues contributing to system failures
- Using **advanced diagnostic tools**
- Providing **clear insights** into the causes of failures.

Our approach following a root cause analysis includes:

- **Developing preventative measures** to increase the resilience of the system.
- **Ensuring smooth and reliable operation** of hydropower plants.
- **Enhancing the longevity** of equipment and minimizing downtime.

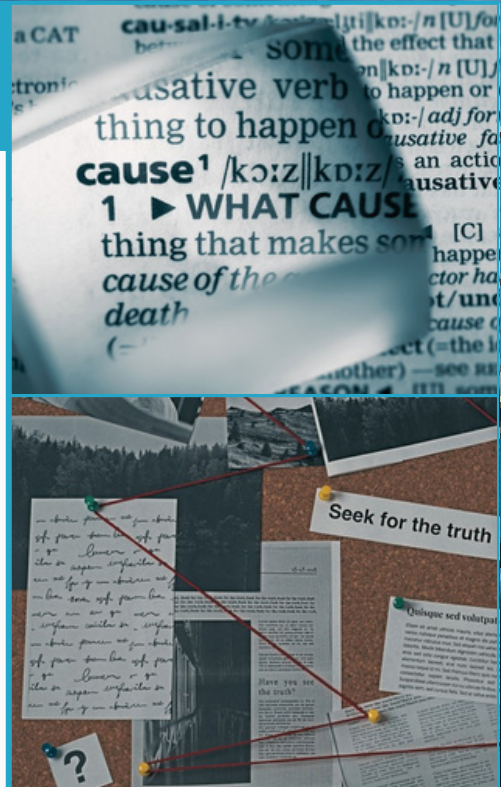

## *Mechanical and Electrical Design, Modelling, & Manufacturing of Components*

We provide detailed design, modelling, and manufacturing using advanced technology to enhance functionality and performance, such as:

- **Runner Design & Manufacturing:** Our innovative solutions optimize flow and efficiency, maximizing performance and reducing waste.
- **Bearing Design and Reverse Engineering:** Durable bearing designs and offer reverse engineering to improve existing models for optimal performance.
- **Technical Specifications for Procurement:** Detailed specifications for electromechanical equipment procurement to ensure smooth processes and optimal equipment selection.

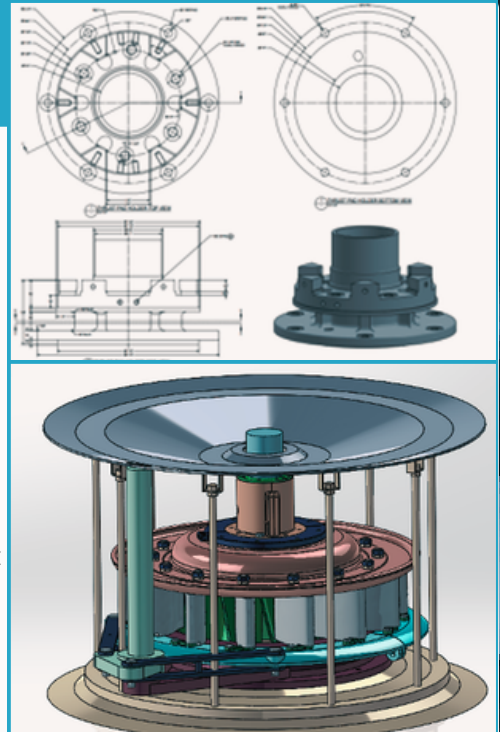



# Projects

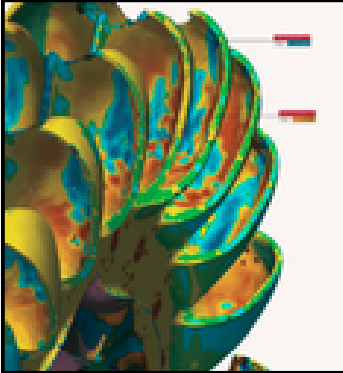

## *Carilafquen-Malalcahuello Hydropower Plant*

*– Melipeuco, Región Araucanía, Chile (Latin America Power)*

We conducted a comprehensive condition assessment of the Pelton Runners at the Carilafquen-Malalcahuello Power Plant in Chile using advanced 3D scanning technology. Additionally, we performed a general condition evaluation of the Carilafquen Units, ensuring optimal performance and reliability.

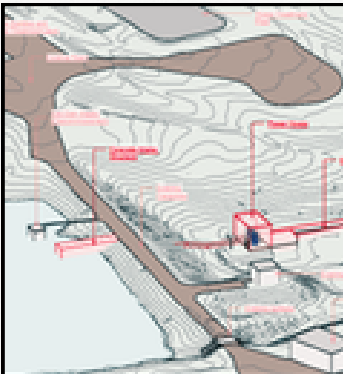

## *Forbes Lake Micro-Hydro Power Plant and Feasibility Study*

*– New Glasgow, Nova Scotia, Canada (Town of New Glasgow)*

A feasibility study was performed to evaluate the potential establishment of a micro-hydro power plant at Forbes Lake, overseen by the New Glasgow Water Utility. The focus of this project was to access solutions for harness water that would otherwise go unused. The main goal of the proposed plant was to manage the water level of the lake while simultaneously generating electricity.

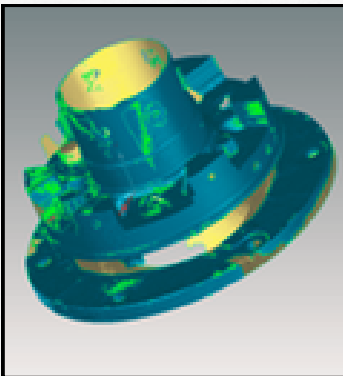

## *Malay 4 Hydropower Unit*

*– Nova Scotia, Canada (Nova Scotia Power)*

Hysovent undertook the reverse engineering of crucial components within the Malay 4 Unit for Nova Scotia Power in Nova Scotia. This project was designed to support the refurbishment efforts and ensure comprehensive documentation. By meticulously analyzing and reconstructing these vital components, we were able to not only extend the lifespan of the hydroelectric unit but also contributed significantly to the optimization of future maintenance and operational strategies.

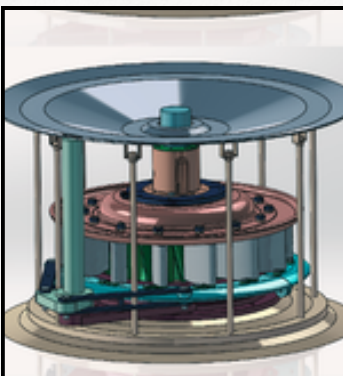

## *Factorydale Hydropower Plant*

*– Berwick, Nova Scotia, Canada (Berwick Electric Commission)*

As the owner's engineers for the Factorydale Hydropower Plant, Hysovent conducted a comprehensive condition assessment and engineering analysis to support our designs of a new generating unit, as well as the ongoing designs for the turbine, trash racks, log booms and additional plant upgrades. Our evaluation and designs will be centered on ensuring the compatibility of existing infrastructure while enhancing the plant's efficiency and sustainability.



# Projects



## *Tests FAT and QAQC Plan Compliance Review*

*– Colbun, Chile (Rucúe Hydroelectric Plant)*

In this project, we traveled to Italy to witness several QAQC tests on two key components of one of the units of the Rucúe Hydroelectric Plant, part of Colbún. Additionally, we independently verified critical dimensions using our 3D scanner.

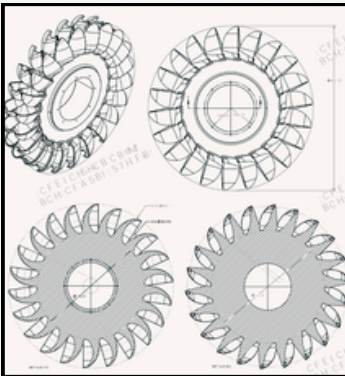

## *Design of a New Pelton Runner – Carilafquen Units*

*– Melipeuco, Región Araucanía, Chile (Latin America Power)*

After evaluating conditions and establishing the root cause of damage to the impellers, we were tasked with improving the design of the original impeller. To achieve this: The geometry of the buckets was modified to enhance water flow and impact, a much more abrasion-resistant alloy is proposed, and a metallic coating far more durable than the current one is suggested.

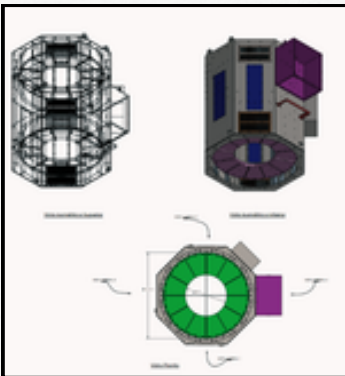

## *Complete Reverse Engineering – Malalcahuello Units*

*– Melipeuco, Región Araucanía, Chile (Latin America Power)*

During the support for the overhaul of one of the Malalcahuello units at the Carilafquén - Malalcahuello plant, a 3D scan of all the mechanical components of the unit was performed, as it lacked detailed plans up to that point. This was done to create a detailed 3D model and detailed plans for use by the plant's operation and maintenance team. Additionally, the lower bearing of the generator was redesigned to extend its lifespan between maintenance periods.



## *Update of the Feasibility Study Module for Hydroelectricity in RETScreen Expert*

*Natural Resources Canada*

Natural Resources Canada chose us for our accumulated expertise in hydroelectricity to update the costs in the feasibility study module for hydroelectric plants, and also to update the formulas for detailed cost estimation of the plants.



# Projects

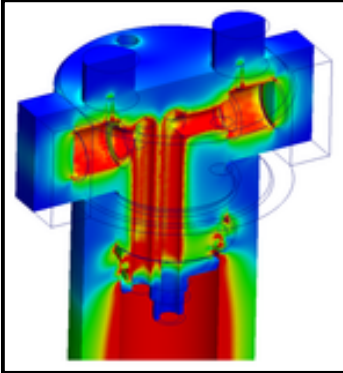

## *Finite Element Analysis (FEA) of Hydraulic Equipment*

*Hydac, Austria*

A structural assessment of hydraulic replacement parts was carried out using Finite Element Analysis, considering multiple operating conditions, material properties, and design configurations. The study verified mechanical strength and supported the preparation of the technical documentation required for certification and commercialization in Canada.

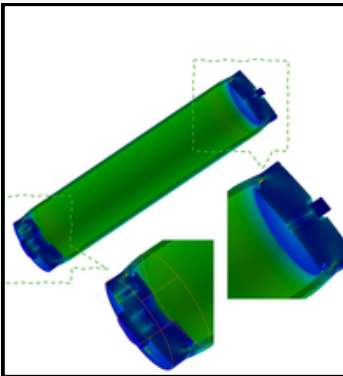

## *Finite Element Analysis (FEA) for Design Improvement*

*Hydroll, Finland*

A structural resistance study of internal machinery components was performed through Finite Element Analysis, evaluating their behavior under various operating conditions and changes in material properties and design. The analysis provided engineering support to identify stress concentrations and define improvements aimed at redesign and product optimization.

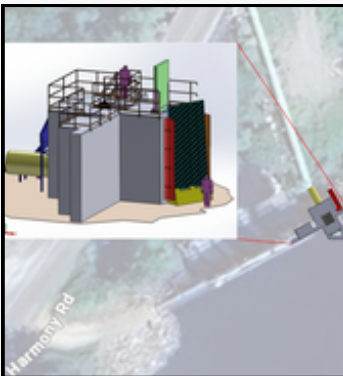

## *Modernization and Upgrading of the Factorydale Intake*

*Berwick Electric Commission, Canada*

The intake structure of the Berwick reservoir was upgraded based on bathymetric diagnostics and hydraulic evaluation. Protection systems against debris and solid transport were optimized, reducing waste accumulation and minimizing the risk of mechanical damage to the turbine.

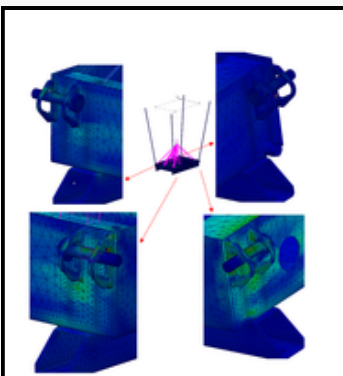

## *Verification of Lifting Element Design for Machinery in Confined Spaces*

*Hydac*

Engineering support was provided for the design and structural verification of lifting lugs integrated into equipment installed in a confined space. Load capacity, stress distribution, and equilibrium conditions during lifting were evaluated to ensure a safe and controlled maneuver. The design was validated according to applicable safety criteria and project standards.



# Team Projects

Our team possesses substantial experience in the field of hydroelectricity, which predates both our their time at Hysovent and even the company's establishment. Here are some examples:



## *Fourth Lake Power Plant*

*Nova Scotia Power - Nova Scotia, Canada*

Complete overhaul of the horizontal Kaplan turbine and redesign of the impeller shaft to eliminate cavitation and increase stable production capacity from 2MW to a maximum of 3.4MW. New mechanical seal, simpler design, remotely monitored. Comprehensive rehabilitation of the penstock. New selected BOP equipment. Total project cost: Over \$2.5MM.

## *Construction of a 280 MW Combined Cycle Hydroelectric Power Plant.*

*North Eastern Ltd.- Sarnia, Ontario, Canada*

Construction of the plant and management of up to 250 unionized workers and 30 supervising engineers to ensure the plant was built on time and with quality. Constructability reviews of all system designs were conducted, as well as interviews and hiring for the construction team, planning of construction methods to minimize the number of subcontractors on site, and authority/supervision of the purchase of construction materials. Additionally, welding procedures for structural steel and power piping were developed, and certification was obtained from the TSSA to build boilers.

## *Technical assessment of wear on Pelton-type turbines (87MW)*

*José Antonio Páez Hydroelectric Plant - Corpoelec, Venezuela*

Detailed analyses of erosion, cavitation, and fatigue patterns in the critical components of the Pelton turbines (87 MW) at the power plant. Advanced technical inspections were carried out through dimensional measurements, specialized visual evaluation, and review of operational history. Identification of root causes of hydraulic and mechanical wear, as well as potential failures associated with operating conditions. Development of preventive and corrective maintenance recommendations aimed at extending the service life of the runners and nozzles. Proposal of improvements in operating parameters and monitoring practices to reduce the rate of deterioration. All these actions strengthened operational reliability and optimized the availability of the hydroelectric plant.

# ★★★★★ *Team Projects*



## *Study of Fractures in Steel Structures and Degradation of the Discharge Ring Anchors of the Caruachi Hydroelectric Plant (2160 MW in 12 Generating Units)*

*Central Hidroeléctrica Caruachi - Corpoelec, Venezuela*

Within the framework of the project, technical documentation was collected and reviewed, field inspections and findings were recorded, fractures in steel elements were identified and characterized, the degradation state of the discharge ring anchors was evaluated, causes and failure mechanisms (fatigue, corrosion, vibrations, and operational conditions) were analyzed, verification calculations and structural integrity assessments (stresses, deformations, and safety margins) were performed, criticality and operational risks were determined, and technical reports with repair, reinforcement, and maintenance action recommendations were prepared to ensure the reliability and availability of the hydroelectric units.

## *Startup, final commissioning, and transition to operation of the Muskrat Falls Hydroelectric Complex (4×206 MW)*

*Newfoundland and Labrador, Canada*

Coordination of operation and maintenance during the final commissioning and start-up of units; leadership of teams (personnel and contractors) for safe and reliable operation; asset management of the complex (powerhouse, dams, and spillway); administration of service contracts; control of budgets and costs (CAPEX/OPEX); implementation of safety procedures; training planning; and monitoring of capital projects and coordination with stakeholders.

## *Mechanical-metallurgical design and integrity assurance for industrial equipment and power generation.*

*Ontario, Canada*

Design and verification of industrial equipment and power systems, including pressure vessels and power transmission; preparation of drawings, calculations, and specifications; selection of materials and definition of manufacturing processes; and technical leadership as an International Welding Engineer (CWB) in welding of pressure vessels (WPS/PQR, inspection and quality control), supported by professional practice as a P.Eng. in Canada.

# Our Hydropower Team



## *Javier Ojeda*

OWNER & PRINCIPLE ENGINEER

Javier, our owner and principal engineer, is internationally certified as a Project Management Professional (PMP), Certified Energy Manager (CEM), and Renewable Energy Professional (REP). With over 20 years of experience in renewable energy, energy efficiency, and hydroelectric power plants, including operations and management of a recent megaproject in Labrador. Javier currently leads our operations for multidisciplinary projects ranging from energy audits to comprehensive overhauls of hydro systems.

OWNER & PRINCIPLE ENGINEER



## *Zenahir Alvarado*

JUNIOR ENERGY ANALYST

Zenahir is our junior energy analyst with a background in electrical engineering. She is skilled in preventive and corrective maintenance, KPI monitoring, and quality systems adhering to ISO standards. In her current role, she focuses on energy management and efficiency, bringing valuable insights into organizing, reviewing, and analyzing energy bills, and document preparation for ASHRAE Level 1 & 2 energy audits. Zenahir is bilingual, fluent in both English and Spanish, and leads our technical translations services between these languages and in social media management.

JUNIOR ENERGY ANALYST



## *Maria Elena Blesa Gomez*

LEAD ENERGY ANALYST, ENGINEER

Maria Elena has over 5 years of experience and holds certifications as a CEM, RETScreen Expert (CRE), and CMVP. With more than five years in energy audits, RETScreen modeling, and GHG quantifications, she has worked with Natural Resources Canada validating energy models for programs like GICB. Skilled in feasibility studies and financial modeling, she supports our energy audit modeling, adhering to IPMVP standards. Bilingual in English and Spanish, she excels in technical training, net-zero planning, and data analysis.

LEAD ENERGY ANALYST, ENGINEER



## Claire Traynor

ENVIRONMENTAL, SUSTAINABILITY, AND REGULATORY COMPLIANCE COORDINATOR

Claire is our lead consultant for environmental management and sustainability, with background in Earth Sciences, Environmental Studies, and Regulatory Policy; certified in environmental impact assessments and communicating sustainability, with proven experience in project management and business development in the environmental sector at AGAT Laboratories. With experience in regulatory processes, environmental compliance, and stakeholder engagement, implementation strategies, data analysis, creating technical reports, and fluency in both Spanish and English, Claire exhibits strong team leadership and problem-solving in collaborative and independent settings,

ESG COMPLIANCE COORDINATOR



## Alberto Capodicasa

BUSINESS DEVELOPMENT COORDINATOR

Alberto, our Business Development Coordinator, has over 20 years in business development and international sales in industrial and energy sectors. He's adept at driving revenue growth and forming strategic alliances globally. Alberto excels in technical sales and managing complex projects like coordinating Factory Acceptance Tests. His expertise spans energy, manufacturing, and road lighting, working with NORD Gear and LED Roadway Lighting. Trained in Metallurgical Engineering, he holds accreditations in International Trade and P.Eng. Known for persuasive communication, he excels in impactful presentations and building long-term relationships.

BUSINESS DEVELOPMENT COORDINATOR



## Pedro Gutierrez

CAD ENGINEER & REVERSE ENGINEERING CONSULTANT

Pedro Gutiérrez is our CAD Engineer and Reverse Engineering Consultant, with over 25 years of experience in modeling, technical documentation, and training. Winner of the Autodesk ATC Instructor of the Year – Northern Latin America (2008), he is proficient in Geomagic, SolidWorks, Solid Edge, Inventor, and Revit, delivering precise, fabrication-ready models and drawings. His expertise in reverse engineering for heavy industries in Latin America drives the recovery and modernization of components, reducing downtime, with a track record alongside clients like Caterpillar and Procter & Gamble.

CAD ENGINEER AND REVERSE ENGINEERING CONSULTANT



## Juan Carlos Marin

SENIOR MECHANICAL ENGINEER

Juan Carlos is one of our Senior Mechanical Engineer with over 25 years of experience, including more than 15 years in hydropower. He has a Master's in Mechanical Engineering and specializes in CFD, FEA, and mechanical vibration analysis. Skilled in 3D scanning and ANSYS simulations, he excels in leading teams through structural failure analysis of hydro unit equipment and conducts engineering inspections. His expertise in diagnosing and resolving complex hydro system failures makes him invaluable.

SENIOR MECHANICAL ENGINEER



## Jesus Ojeda

SENIOR ELECTRICAL ENGINEERING CONSULTANT

Jesus is our Senior Electrical Engineering Consultant with over 20 years as a Senior Electrical Engineer, he brings extensive expertise in electrical systems and project coordination. He specializes in energy efficiency and energy audits, having developed Energy Efficiency and Savings Studies under ISO 50001:2018 standards for various industrial clients. His experience in reviewing and coordinating complex engineering projects ensures compliance and efficiency, while his leadership and adaptability enhance team collaboration and continuous improvement.

SENIOR ELECTRICAL ENGINEERING CONSULTANT

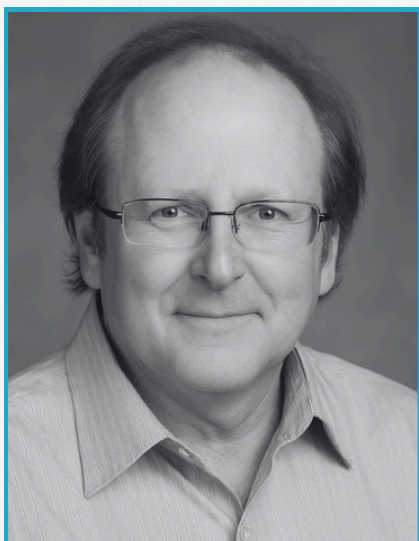

## Mike Detenbeck

MECHANICAL AND METALLURGICAL DESIGN SPECIALIST & SENIOR HYDRO CONSULTANT

Mike has over 48 years of experience in mechanical and metallurgical design. He specializes in forensic engineering and turbine overhauls, including Francis, Pelton, and Kaplan models having crafted engineering instructions and specifications for each type. He has overseen the production of components such as runners, shafts, and seals for hydro plants. Mike also consults on pressure vessels, welding, structural, and conveyor systems. Mike led the construction of a 280 MW Combined Cycle Power Plant, focusing on minimizing subcontractor use and maximizing local resources.

SENIOR MECHANICAL HYDRO ENGINEER

# HYSOVENT

sustainable engineering



## CONTACT US

**JAVIER OJEDA**

**President and Owner**

Email: [javier@hysovent.com](mailto:javier@hysovent.com)

Phone: +1 (902) 210-6828

Location:

103-287 Lacewood Drive,  
Suite 121.

Halifax, NS, B3M3Y7, Canada

Email:

[info@hysovent.com](mailto:info@hysovent.com)

Phone:

+1 (902) 210-6828

Website:

[www.hysovent.com](http://www.hysovent.com)